

Reinhold Environmental Ltd.



2008 NOx-Combustion Round
Table & Expo Presentation

February 4-5, 2008 in Richmond, VA

A photograph of an industrial facility, likely a power plant or refinery, featuring a tall, white, cylindrical smokestack on the left and a complex network of green steel structures, including scaffolding and walkways, in the center and right. The sky is a clear, pale blue. A semi-transparent blue rectangular box with a grid pattern is overlaid on the center of the image, containing yellow text.

NO_x-COMBUSTION ROUND TABLE

Feb. 5, 2008 – 11:00 AM to 12:30 PM

PANEL IV:

SCR Catalyst Testing Protocol

Moderator: Dave Broske, *EPRI*

The background of the slide is a photograph of an industrial facility. On the left, a tall, cylindrical smokestack rises into the sky. To its right is a large, complex metal structure, possibly a reactor or a distillation column, with multiple levels and a lattice of beams. The sky is a clear, pale blue. The entire image is overlaid with a semi-transparent blue grid pattern.

PRESENTATION

SCR Catalyst Testing Protocol

Presenters

**Larry Muzio, *Fossil Energy Research Corp.* and
Scott Hinton, *WS Hinton and Associates***



SCR Catalyst Testing Protocol

L. Muzio,
FERCo
Laguna Hills, CA

S. Hinton
W. S. Hinton Associates
Gulf Breeze, FL

D. Broske
EPRI
Charlotte, NC

2008 NO_x-Combustion Round Table
Richmond, VA
Oct 4-5, 2008

Objective

Develop recommended and uniform procedures for the testing of SCR catalyst samples

Catalyst Management

Managing the addition or replacement of individual catalyst layers to maintain the NO_x removal and NH₃ slip performance requires accurate knowledge of the activity

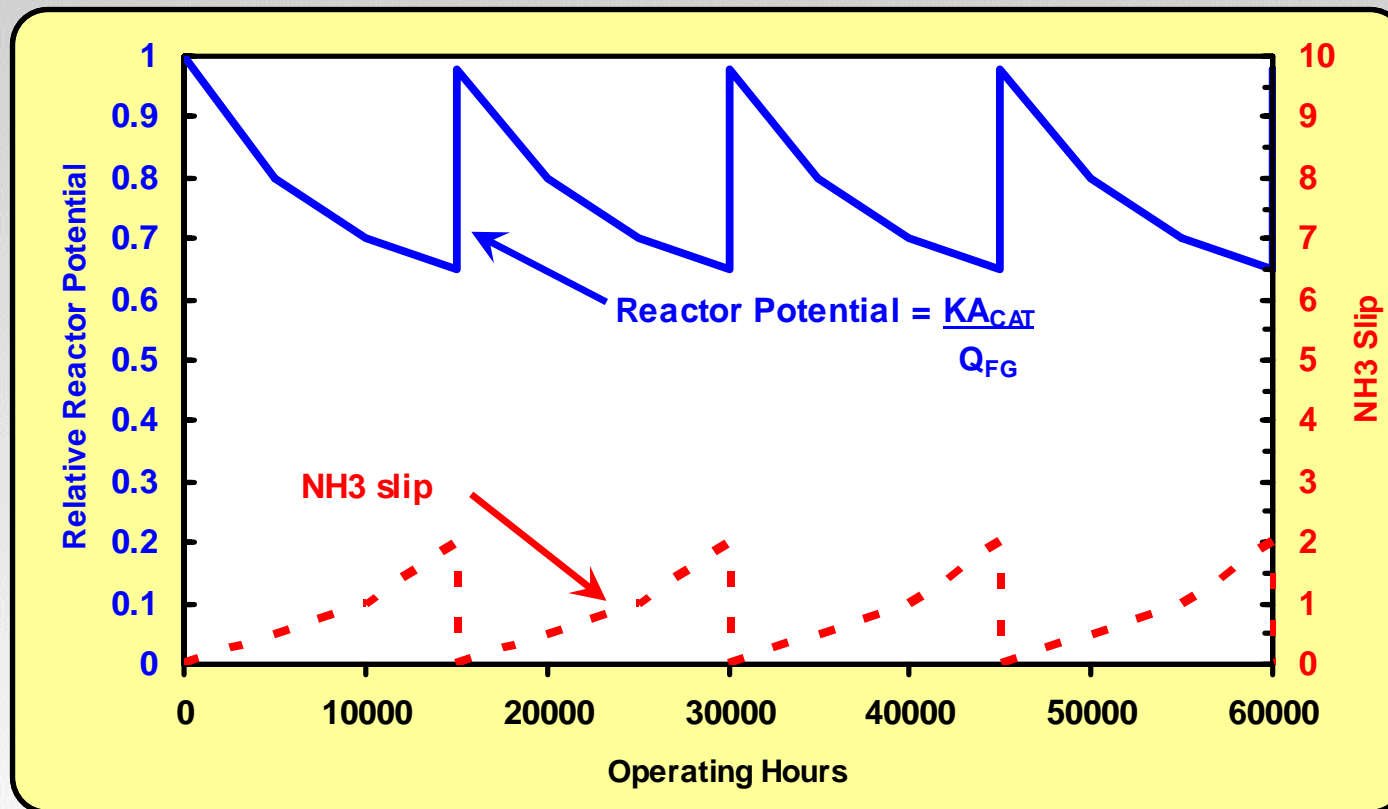

Typical Example of K/Ko for a Layer of Catalyst

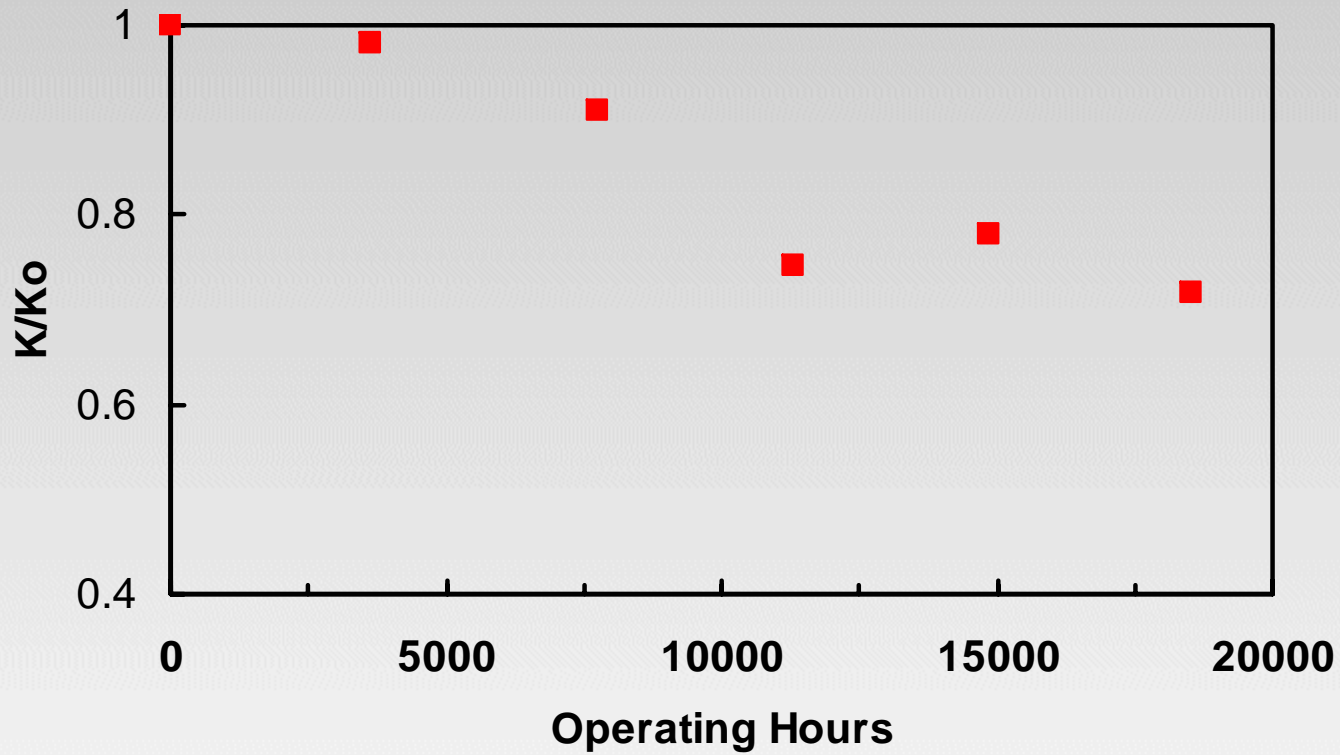

Areas Covered by the Protocol

- **Catalyst Activity**
- **SO₂ to SO₃ Conversion**
- **Chemical Properties**
- **Physical Properties**

Industry Review

- **Establish a dialog with SCR industry organizations with catalyst testing interest and expertise**
- **Assess the protocol's technical material for appropriateness, completeness, and accuracy**
- **Identify areas where further investigation is needed**
- **Strive for consensus in the industry**

Industry Review

- **Program 73 Funders**

- Southern Company..... April Sibley, Jared Cannon
- Consumers Energy..... Tom Davey
- New York Power Authority... Kolli Rao

- **SCR Product and Service Providers**

- Argillon..... Bruce Gobbel
- CERAM..... John Cochran
- Cormetech..... Chris DiFrancesco
- E.ON Engineering..... Thorsten Dux, Terry Smith
- Haldor Topsoe..... Flemming Hansen
- Hitachi..... Isato (Ike) Morita
- SCR-Tech..... Howard Franklin
- Steag LLC..... Hans Hartenstein, Marilyn Martin

Drawing on Existing Protocols

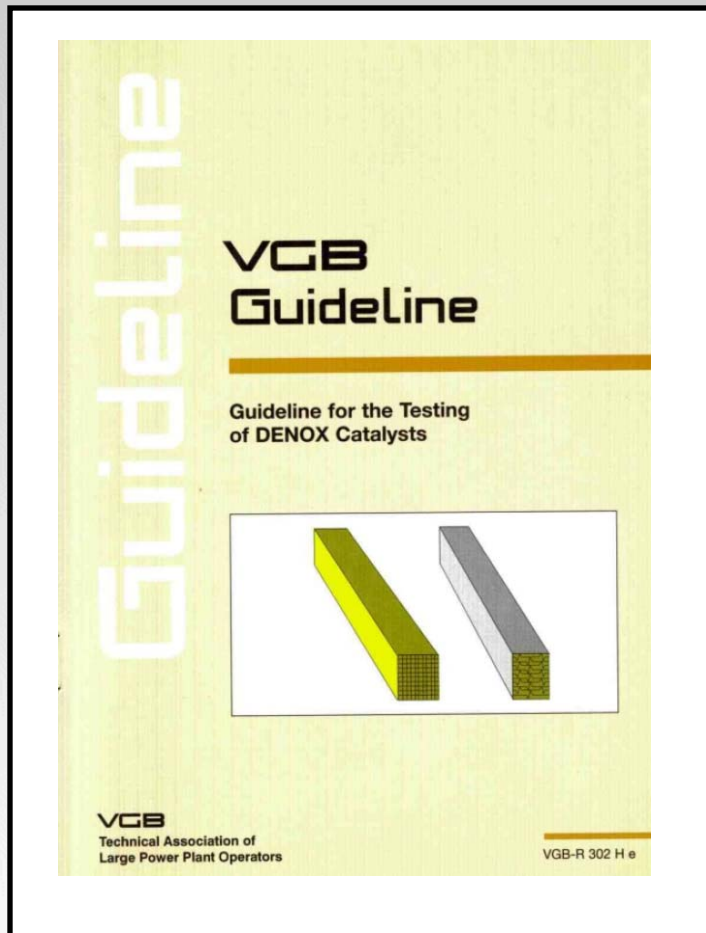

steag LLC

**“Supplement to the VGB R302He
2nd Edition- Common Best
Practices for Bench Scale Reactor
Testing and Chemical Analysis of
SCR DNOx Catalyst” Revision 1,
May 2006**

Catalyst Activity: Definition & Measurement

- Based on a 1-D Steady State Analysis

- Definition

- $\eta_{\text{NO}_x} = 1 - \exp(-K/A_v)$

- $K = [1/K_{\text{chem}} + 1/h_m]^{-1}$

K_{chem} = reaction rate constant

h_m = mass transfer coefficient

- Measuring Activity

- $\text{NH}_3/\text{NO}_x \geq 1$

- Measure NO_x reduction

- $K = -A_v \ln(1 - \eta_{\text{NO}_x})$

Activity Measuring Apparatus: Bench Reactors

- Most handle a full block of honeycomb catalyst
- (or comparable test modules made of plate catalyst)
- Typical 6" by 6" block, 1 – 4 m long
- Primary Use: determination of K (absolute value)



E.ON's SCR Catalyst Test Reactor

Activity Measuring Apparatus: Micro Reactor



Test small pieces of catalyst

- Honeycomb sample: ~ 1" diameter by ~ 6" long
- Plate sample: 0.5" – 1" wide by 4" – 6" long
- Primary Uses:
 - Production control of new catalyst
 - Comparing catalyst types
 - K/Ko determination

Issues Measuring Activity

- Should test conditions simulate full scale operating conditions or conform to a set of operating conditions by a test lab?
- How does the measured activity depend on the test condition?

$$K = [1/K_{chem} + 1/h_m]^{-1}$$

$$Sh = \frac{h_m d_h}{D} = 2.976 \left[1 + 0.095 \left(\frac{d_h^2 u}{LD} \right)^{0.45} \right]$$

This term depends on the catalyst geometry and test conditions

(Tranconi and Beretta)

- Mass transfer rate decreases along the length as flow changes from turbulent to laminar
- Activity is not just a property of the catalyst material

Effect of Test Conditions on Measured Activity

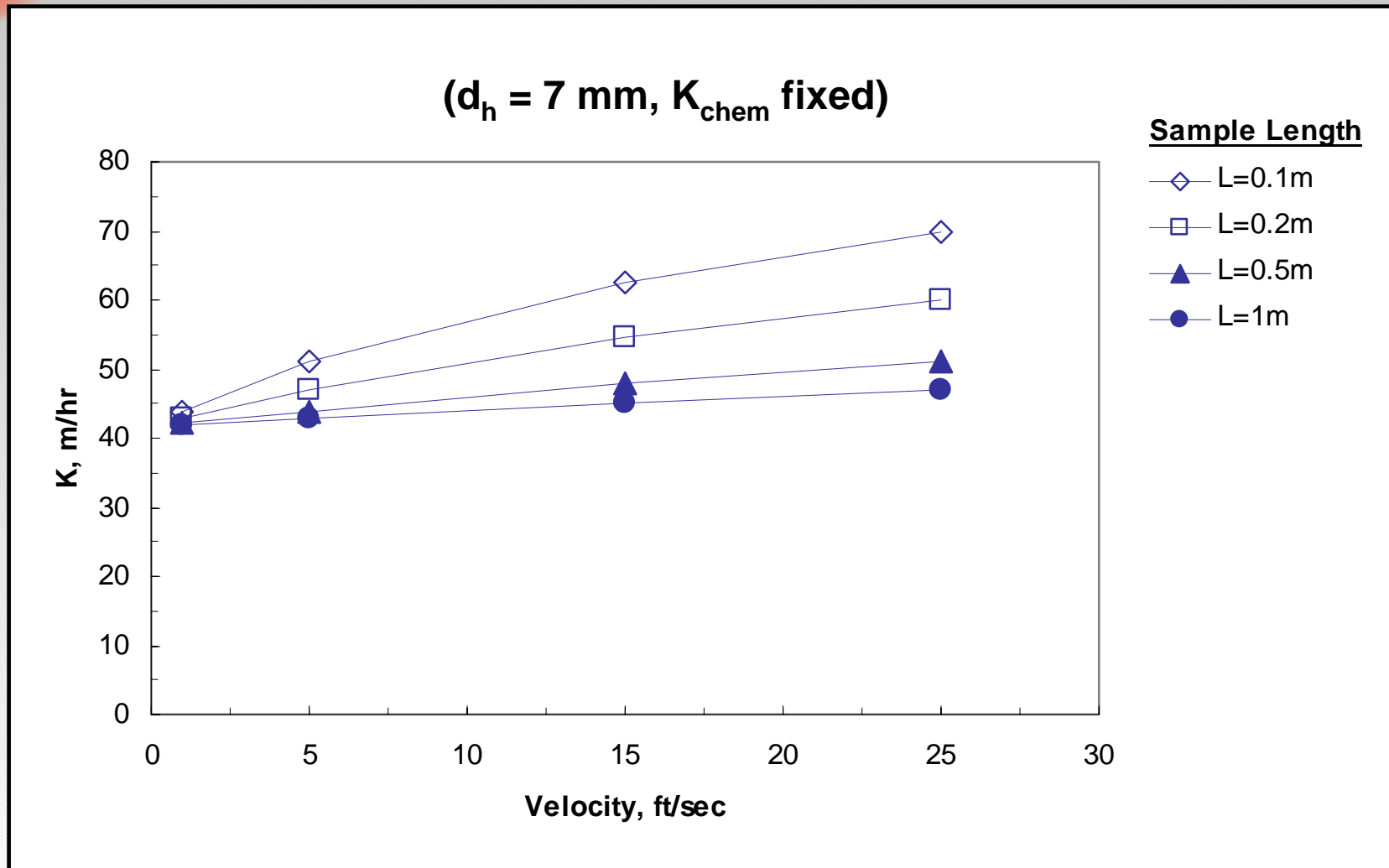

Activity Tests To Support Protocol

- Tests to establish equilibration times for Activity
- New and used honeycomb catalyst
- Activity measured nominally every 0.75 hours for 17 hours

Activity Tests: New Material

Note: Current Protocol specifies 12 hours with no trend

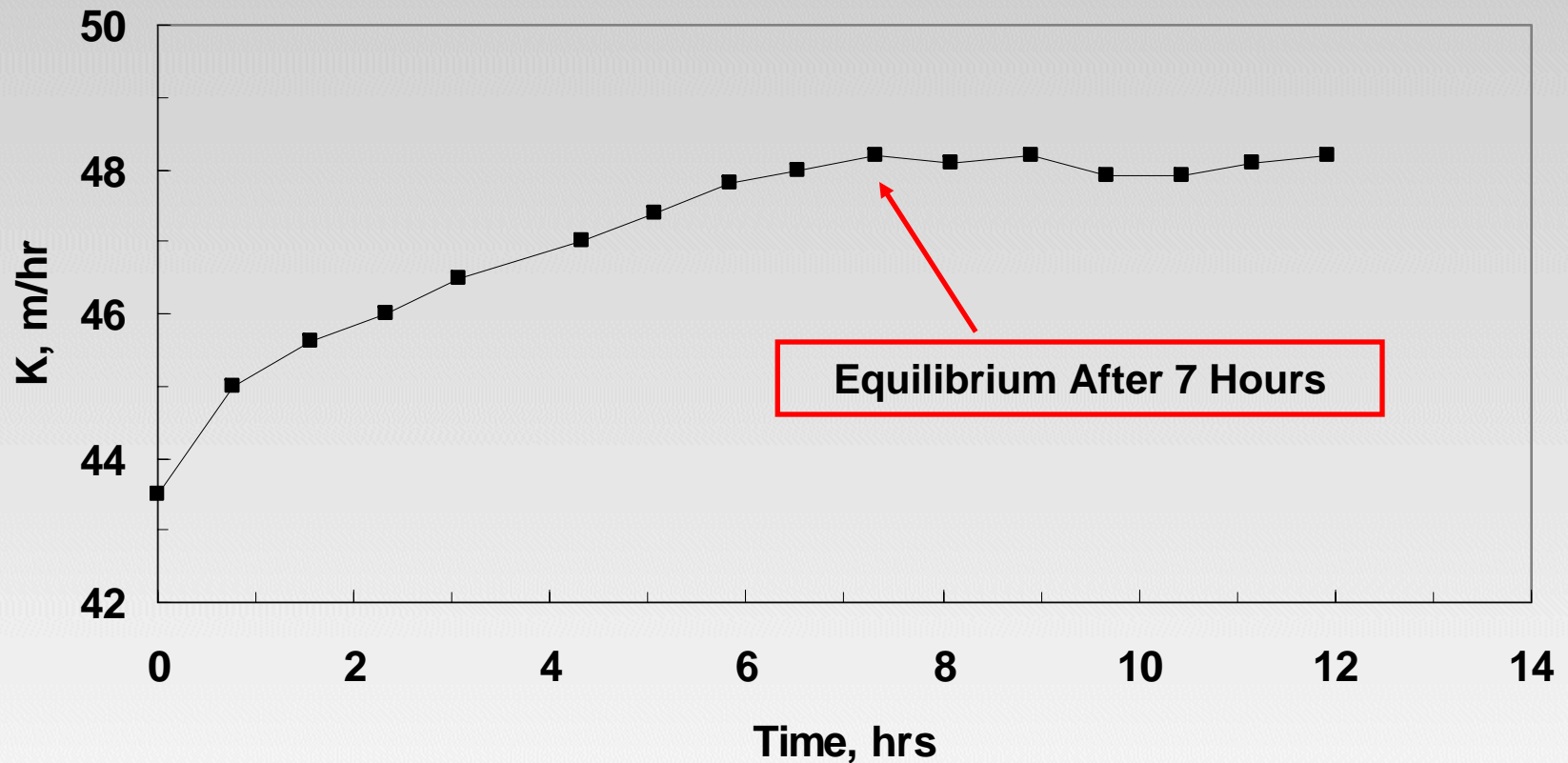

Activity Tests: Used Material

Note: Current Protocol did not distinguish between “New: and “Used” catalyst samples

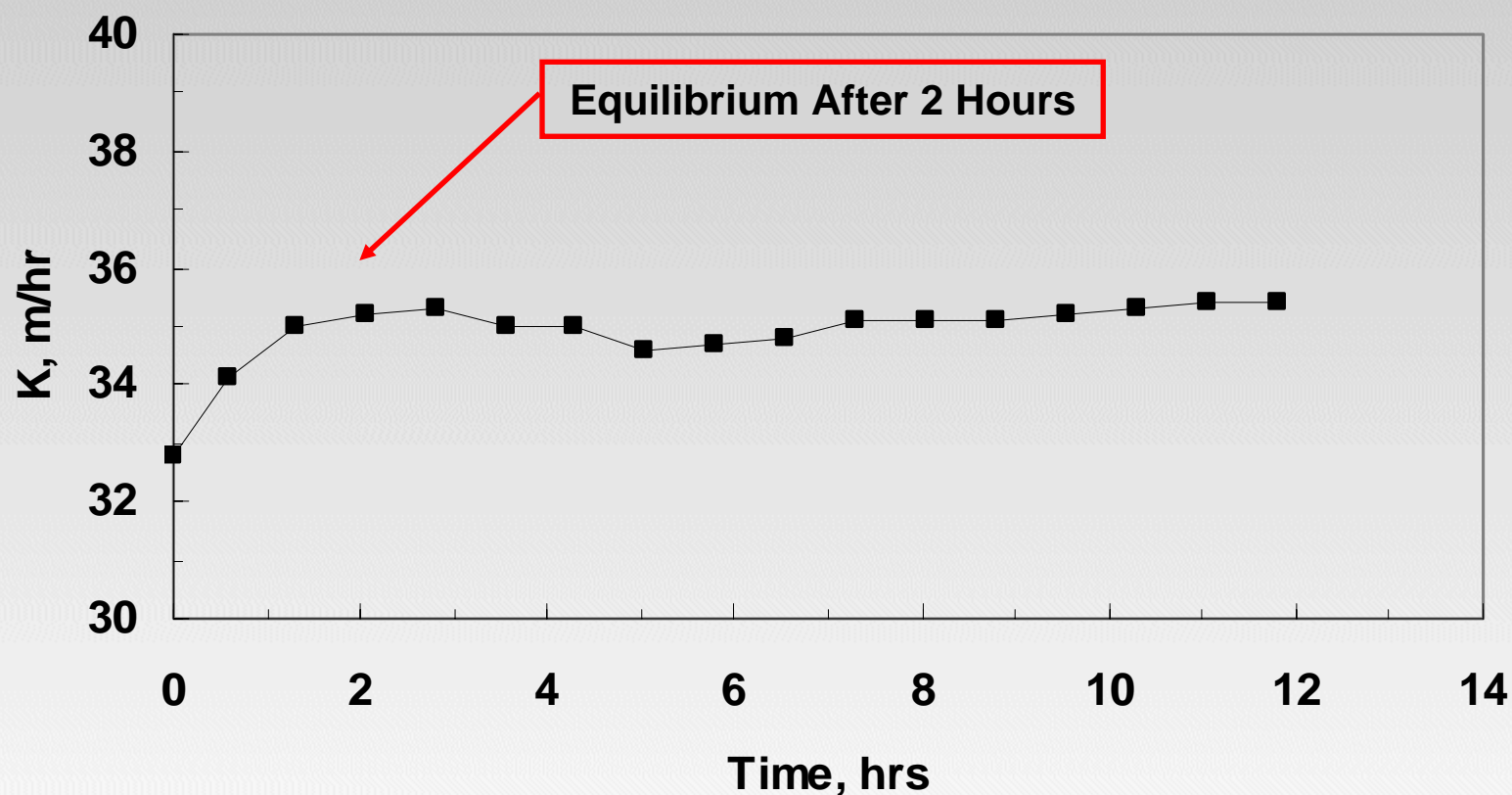

Examples of Test Equilibrium

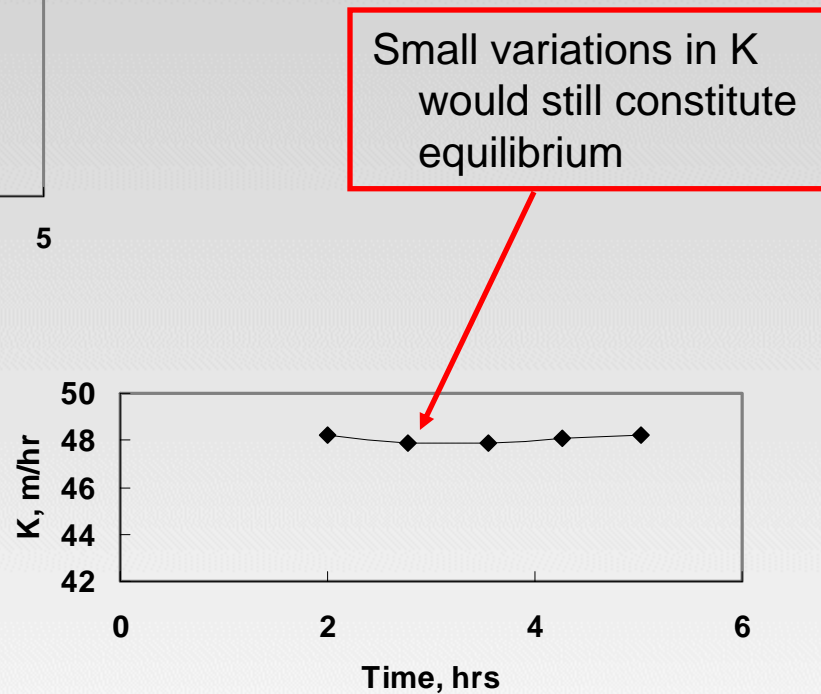
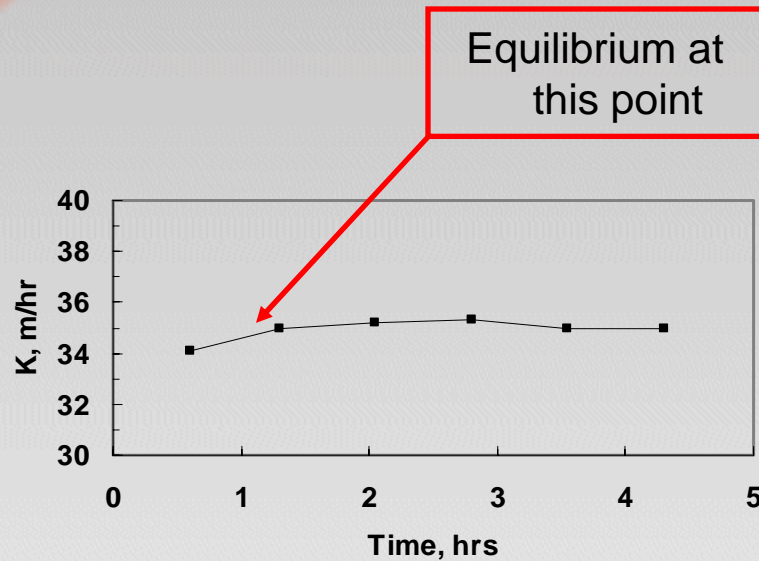

Effect of the Number of Tests on K

Note: The Protocol specifies 4 tests with no trend. The 2nd Edition will maintain 4 tests but specify that an hour elapse between the end of one test and beginning of the next test

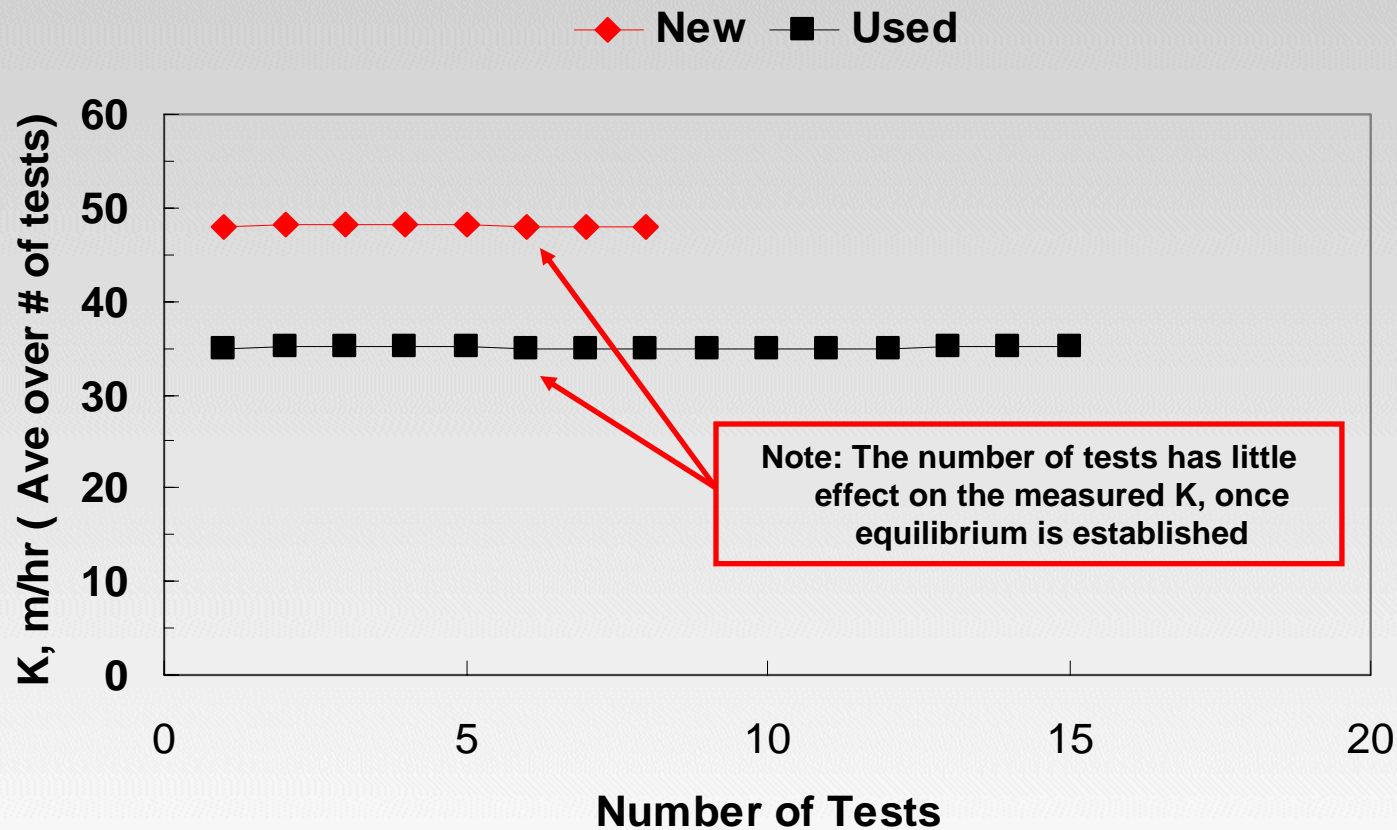

Water Vapor Content

- Protocol specified test gas to have the same H₂O content as full scale
- Impractical as facilities typically fire natural gas or propane
- Revised protocol specifies as generated H₂O along with a correction curve

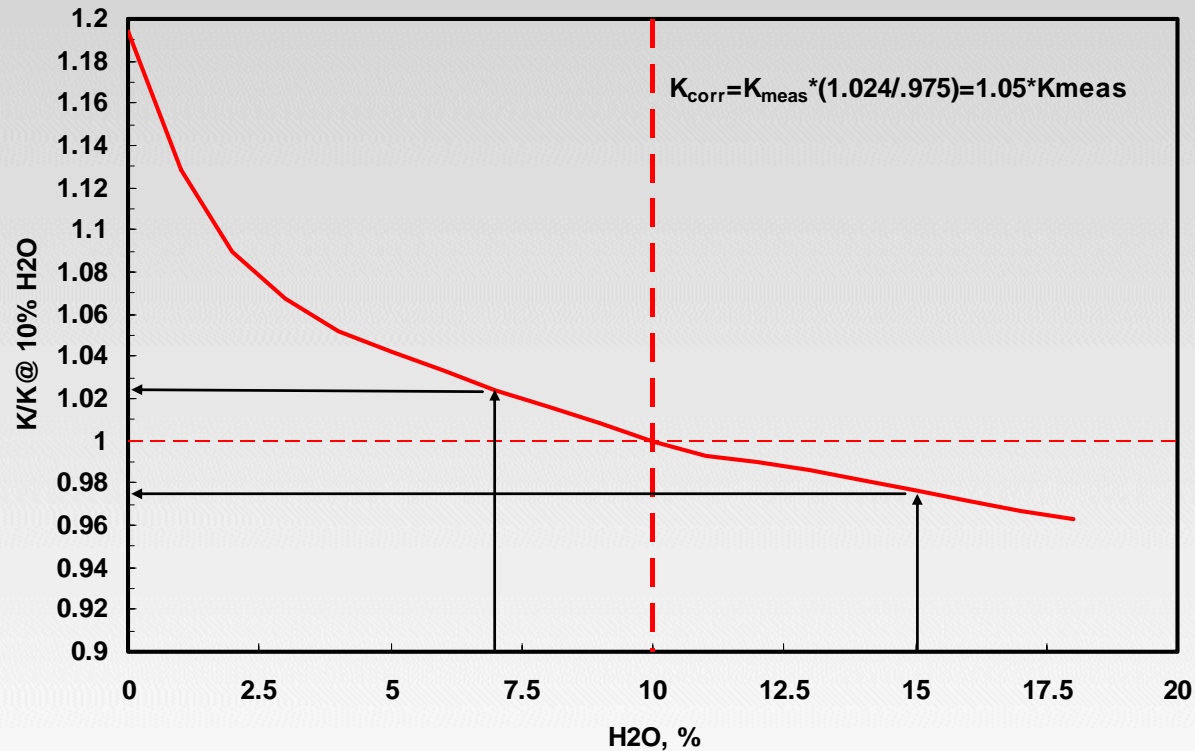

SO₂ to SO₃ Conversion

- Not described by a simple equation
- More kinetically limited than NO_x conversion
- Conversion is highly temperature dependent
- Conversion can depend on the amount of NH₃ present
- Measurements can be difficult
(i.e. 500 ppm SO₂, 0.17% per layer means detecting < 1 ppm SO₃ or a change of <1 ppm SO₂)
- Conditioning times can be long and vary between new, used, and regenerated catalyst
- Measure the change in SO₂ or SO₃?
- If measuring SO₃, can it be done if NH₃ is present?
- Dealing with plugged cells is different than with activity

Conditioning Times for SO₂ Conversion

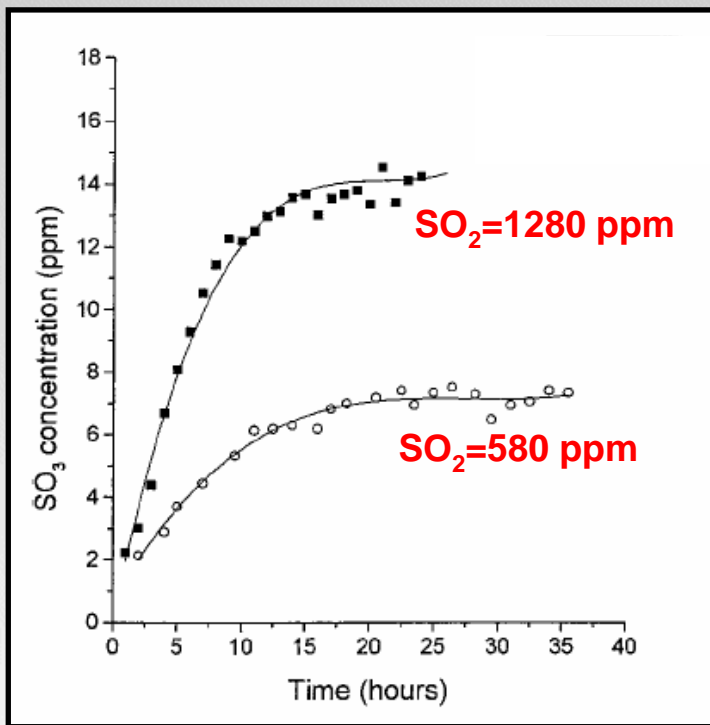

Case A:
T=715F

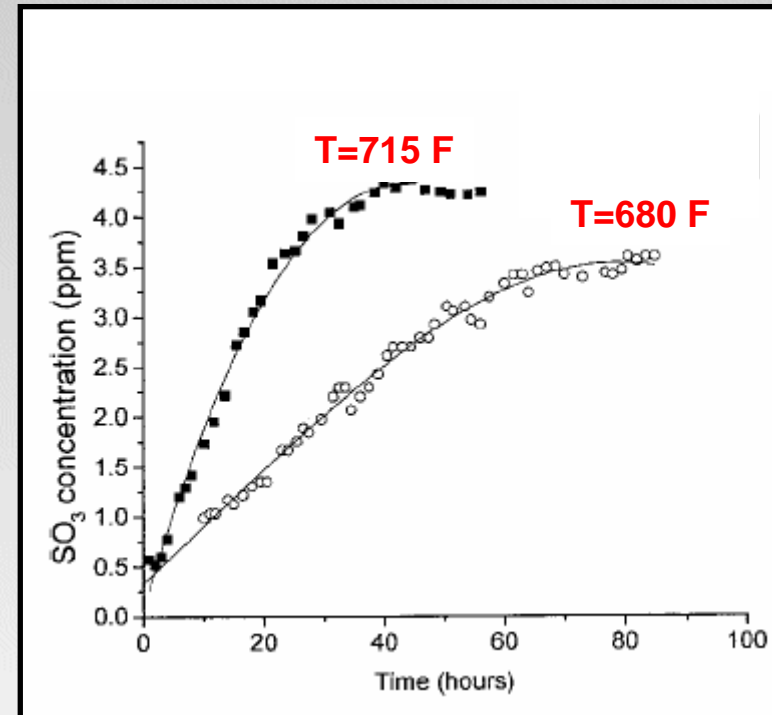

Case B:
SO₂=580 ppm

NH₃ Impacts on SO₂ Conversion

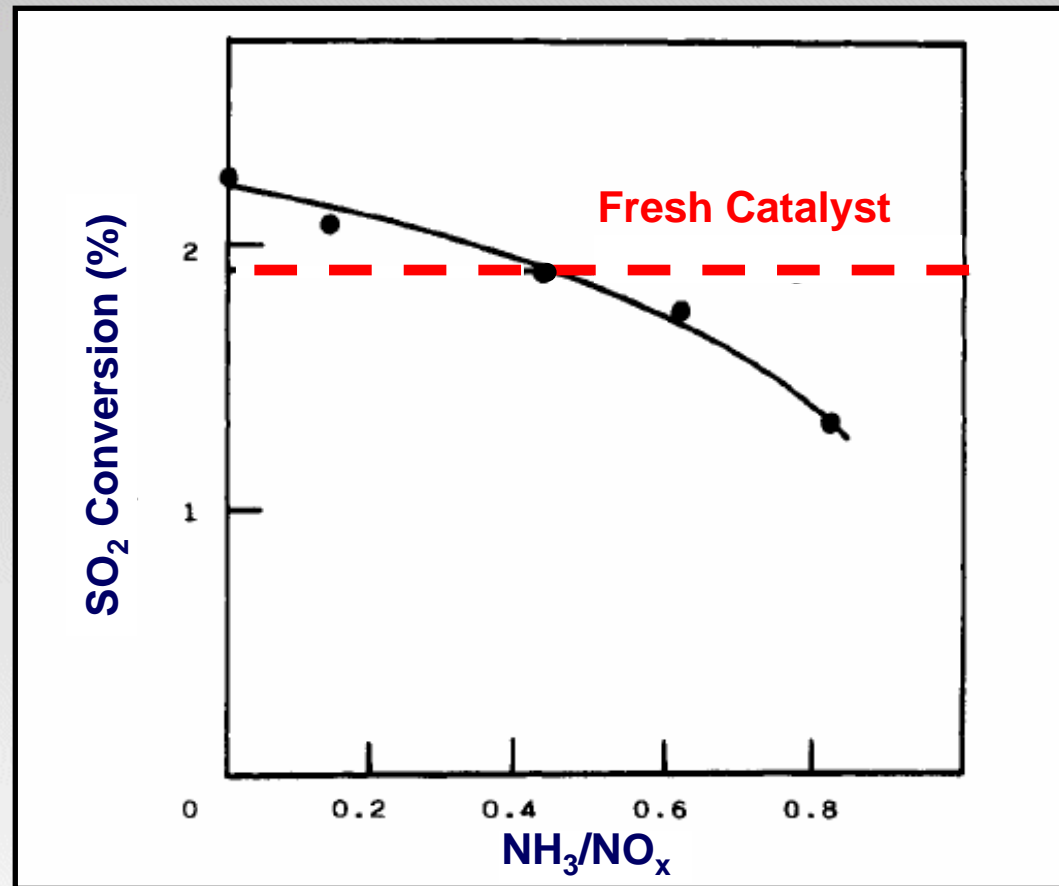

T=716 F, 1000 ppm SO₂, 500 ppm NO_x

SO₂ Oxidation Testing: Accuracy

- Controlled Condensation measurement probably accurate to +/- 0.5 ppm
- This can impact the accuracy of the SO₂ to SO₃ conversion measurement

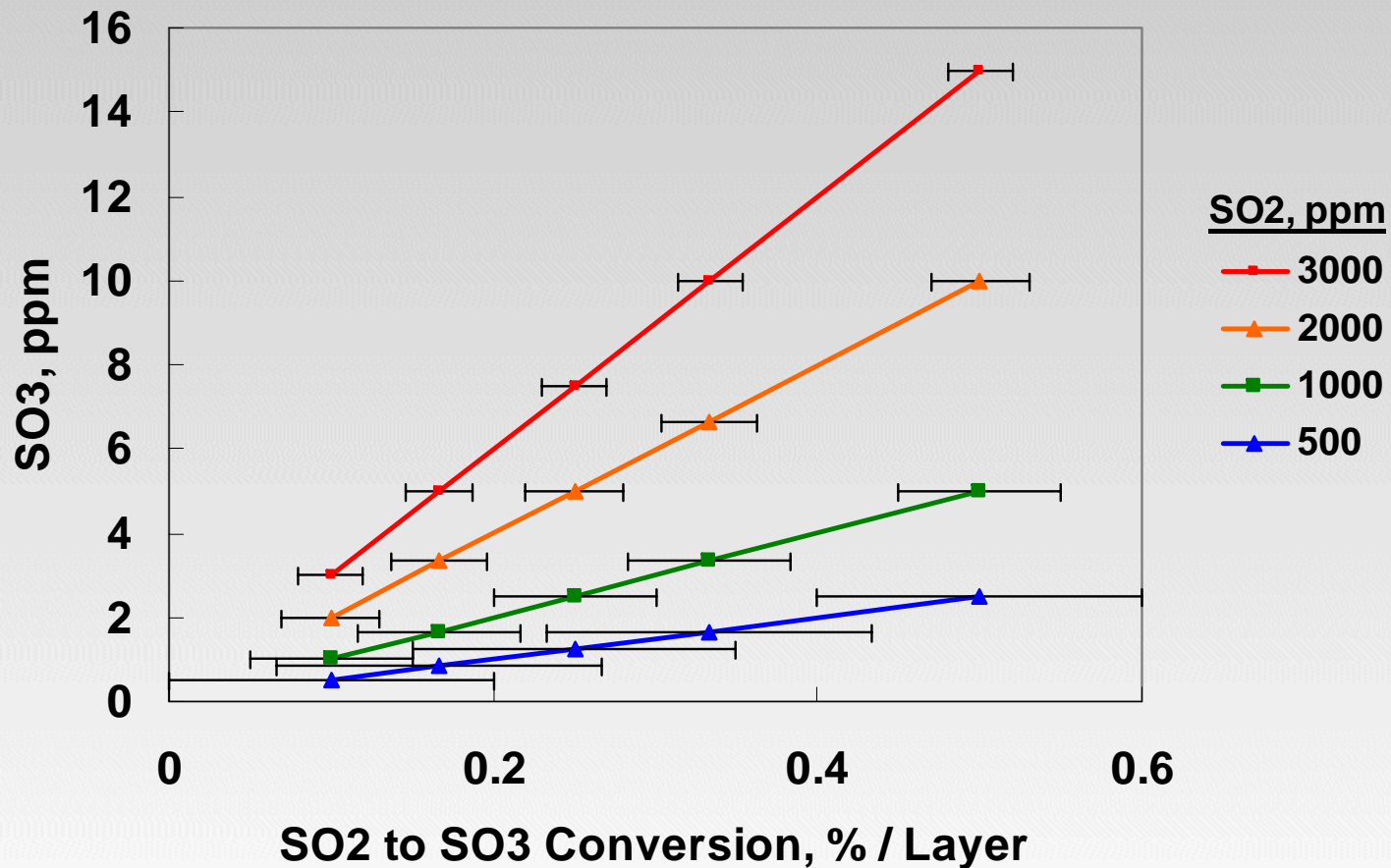

SO₂ Oxidation Testing: Cell Blockage

- For Activity testing the gas flow is adjusted to account for plugged cells
- Since SO₂ oxidation occurs over the entire catalyst volume, not just the surface, this flow adjustment may not be correct for SO₂ oxidation
- The amount of catalyst volume removed depends on the pattern of the plugging not just the absolute amount

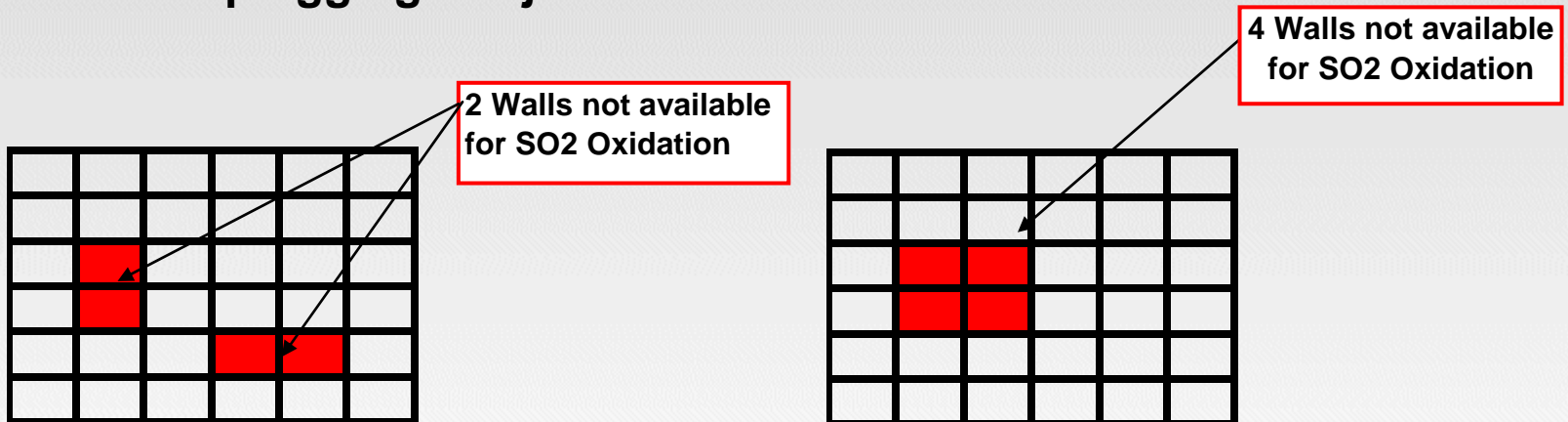

SO₃ Measurement: Controlled Condensation

Controlled Condensation System (CCS) Sampling Train

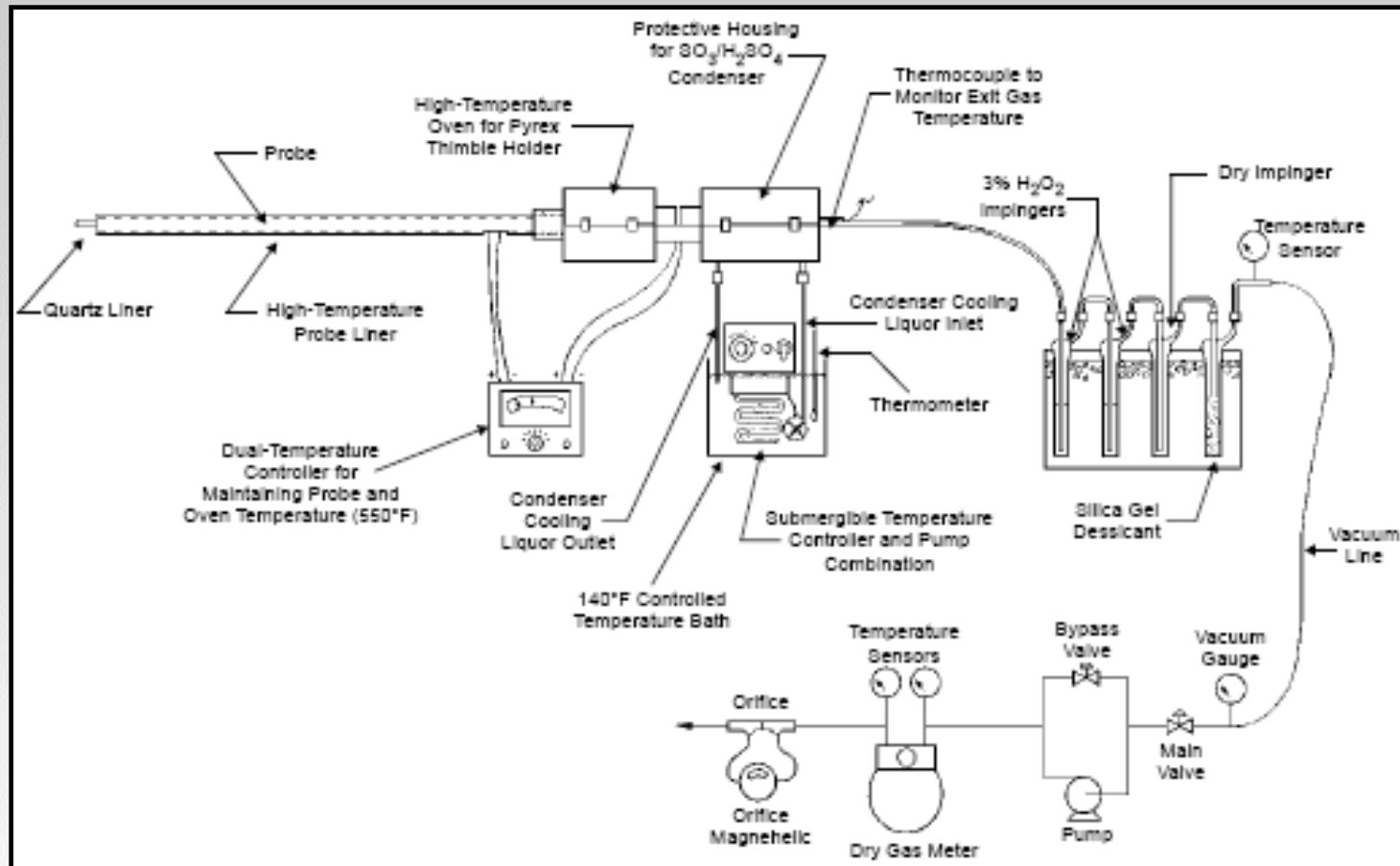

SO₃ Measurement: Controlled Condensation

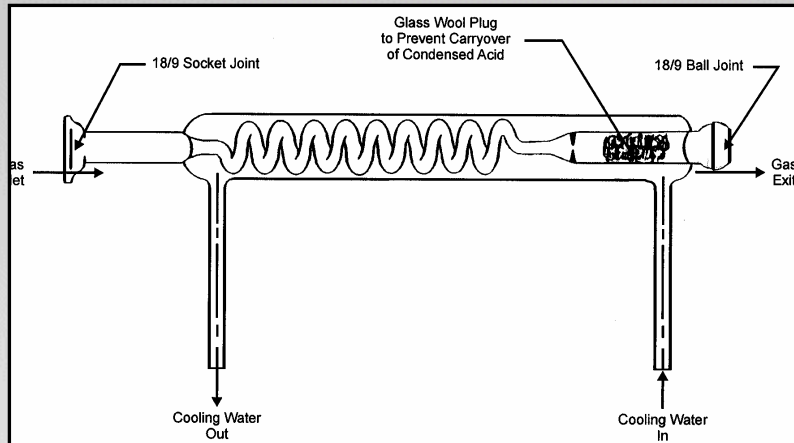

Graham condenser with glass wool plug

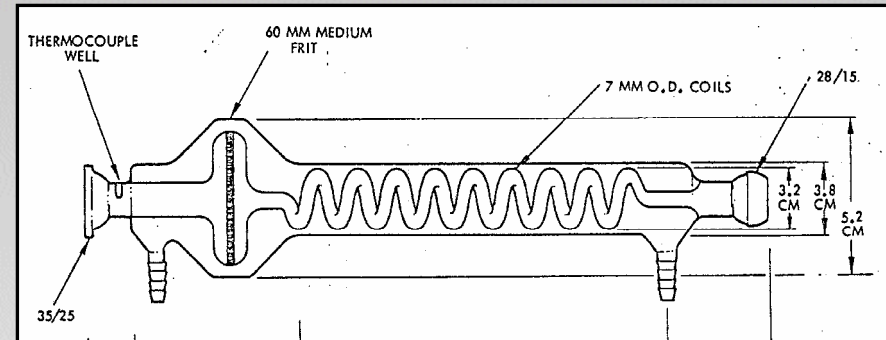

Modified Graham condenser with glass frit (Method 8a)

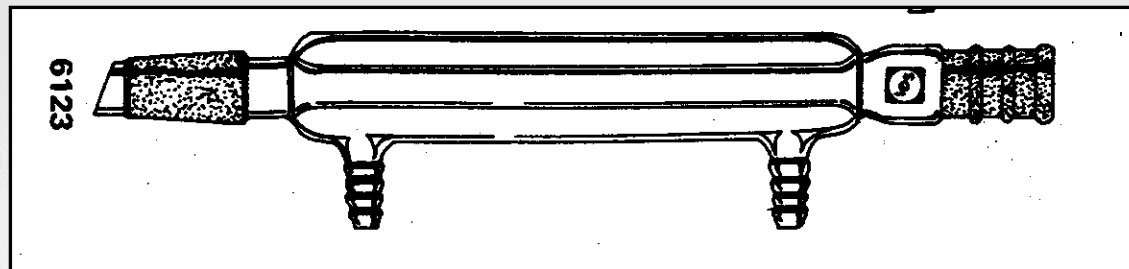

Liebig Condenser with glass wool packing

Summary of the Activity and SO₂ Oxidation Testing Protocol

Parameter	Test	
	Activity	SO ₂ Oxidation
Apparatus	Bench Scale Reactor	
Sample size Honeycomb/Corrugated	150mm x150mm x Full Layer Length	
Plate	150mm x150mm x Half or Full Layer Length	
Temperature	Full Scale	
Flow	Match Full Scale Linear Velocity	
O ₂	Full Scale	
CO ₂	As Generated	
H ₂ O	As Generated	
SO ₂	Full Scale	
NO _x	Full Scale	
SO ₃	None Added	
NH ₃ /NO _x	1.0	0
Conditioning Time	New: 8 hrs and equilibrium Used: 2.5 hrs and equilibrium	36 hrs and equilibrium NH ₃ off after Activity Test for 2 hrs
Measurements	ΔNO _x	ΔSO ₃ or ΔSO ₂
No. of Tests	4	3
Calculations	$K = -A_v \ln(1 - \eta_{NO_x})$	%SO ₂ Oxidation

Physical Properties – Survey Results

- **BET Surface Area**
 - (single point)

- **Pore Volume and Pore Size Distribution**
(Hg Porosimetry)

- **Geometry and Physical Strength**
Optional ?

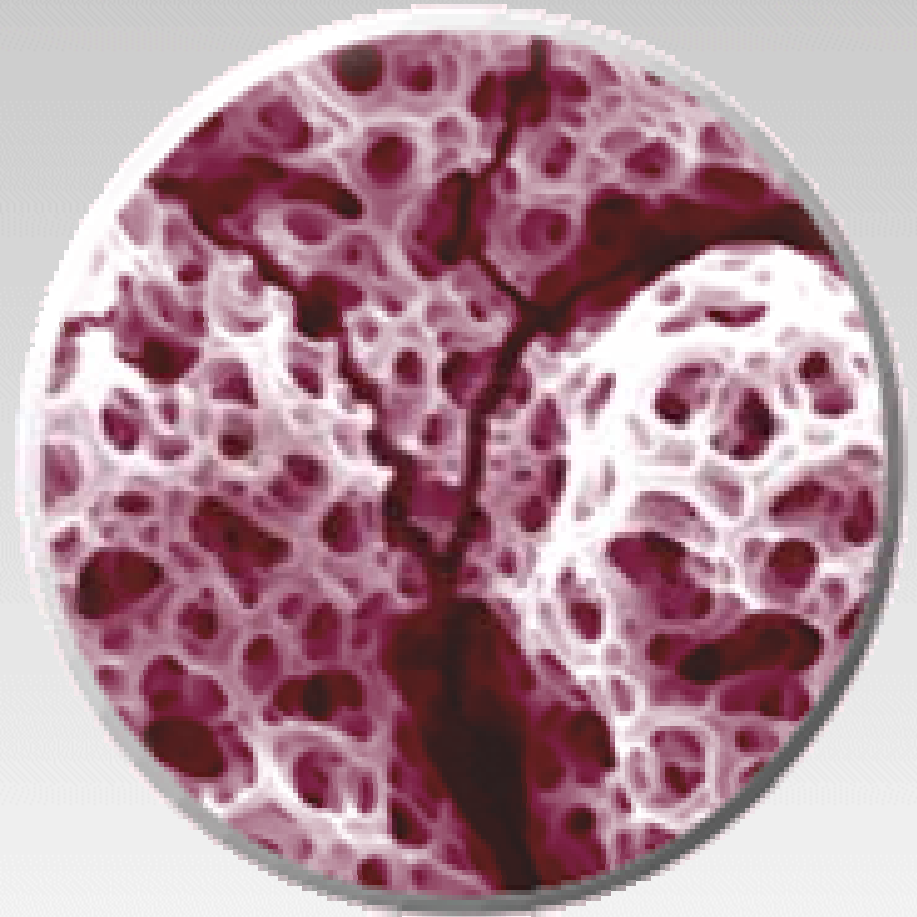

Physical Testing Procedures

Parameter	Catalyst Type	Preferred Test Method
Geometry	All	Direct Dimensional Measurement
Compressive Strength	Honeycomb, Corrugated	ASTM C133-97
Bend Strength	Honeycomb	Specialized Procedure
Bond Strength	Plate	ASTM D522-93a and Alternate ^[1]
Abrasion Resistance	All	ASTM C704-01
Abrasion Resistance	Plate	Alternate Procedure
Surface Area	All	Single-Point BET using Nitrogen
Pore Volume and Distribution	All	Hg Porosimetry or Gas Adsorption

Physical Testing Procedures

Bend Strength Test- Honeycomb

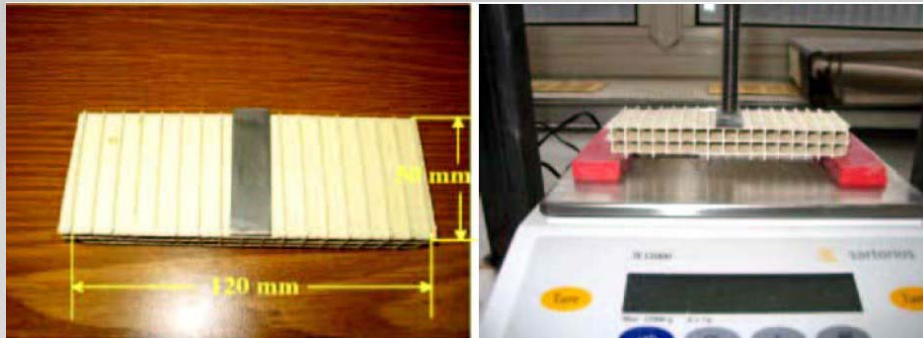

Abrasion Test

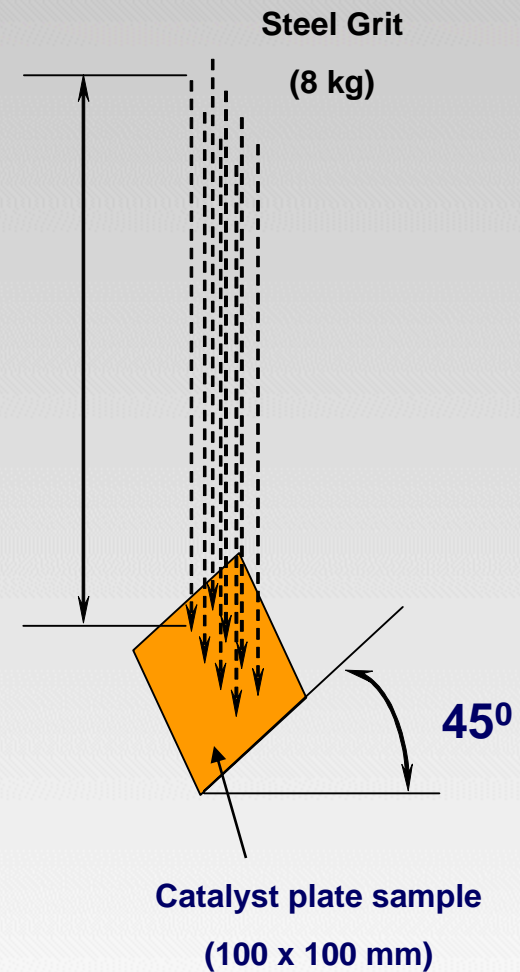

Bond Test- Plate Catalyst

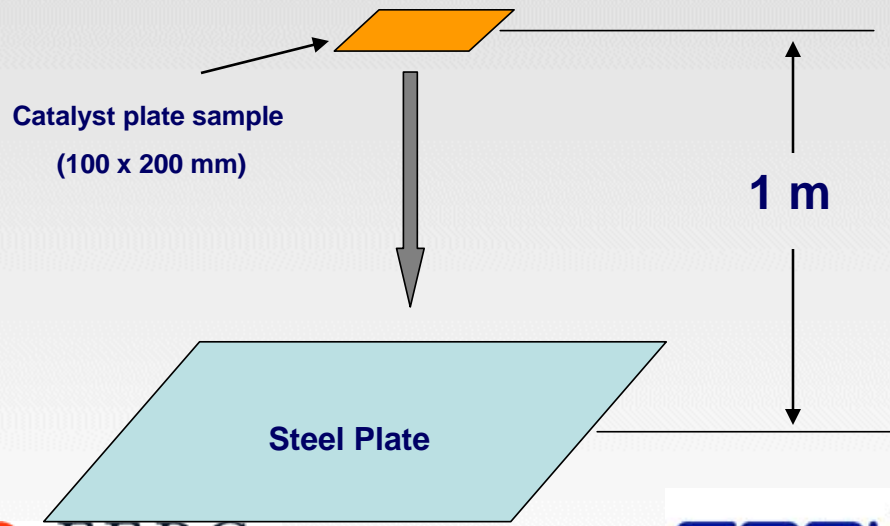

Chemical Analysis – Survey Results

- XRF is referenced as a preferred chemical analysis procedure (bulk and surface)
- Bulk and surface analysis to include:
Al, As, Ca, Fe, K, Mg, Mo, Na, P, Si, S, Ti, V, W
- Analytical techniques may vary, but reporting convention should be standardized.
- Limits of detection/repeatability
- Number of samples – location of samples

Current Plan

“Protocol for Laboratory Testing SCR Catalyst Samples: Second Edition”, 1014256, Technical Update, Dec. 2007

Supersedes

“Protocol for Laboratory Testing SCR Catalyst Samples”, 1012666, Final Report, Dec. 2006

Hg Oxidation :Current Industry Status

- Initially Hg Oxidation was to be included in the Protocol
- Poorly understood relative to NO_x Activity and SO₂ Conversion
- Relatively few laboratories capable of performing the analysis
- No consensus on detailed mechanism of mercury oxidation
- At this point Hg oxidation is not addressed in the Protocol

Future Plans

- *The Catalyst Testing Protocol is intended to be an evolving document*
- Round Robin Testing (Activity, SO₂ Oxidation) -**2008**
- Test Validation SO₂ Oxidation-**Future**
 - **Required Conditioning Times**
 - **Cell Blockage Effects on SO₂ Oxidation**
 - **Overall Precision of the Oxidation Measurement**
- Hg Oxidation- **2008+**
 - **Monitor the State-of-the Art for Laboratory Testing of Catalysts**
 - **Exploratory Tests (Test Conditions, Measurement Methods**

Summary: Chemical Properties

Chemical Properties	
Bulk Analysis	Atomic Absorption (AA) Inductively Coupled Plasma (ICP) Wet Chemical X-Ray Fluorescence (XRF)
Surface Analysis	X-Ray Fluorescence (XRF) Electron Microscope
Species of Interest	Al ₂ O ₃ , As, CaO, Fe ₂ O ₃ , P ₂ O ₅ , K ₂ O, MgO, MoO ₃ , Na ₂ O, SiO ₂ , TiO ₂ , V ₂ O ₅ , WO ₃

Summary: Physical Properties

Physical Properties		
Parameter	Catalyst Type	Preferred Test Method
Geometry	All	Direct Dimensional Measurement
Compressive Strength	Honeycomb, Corrugated	ASTM C133-97
Bend Strength	Honeycomb	Specialized Procedure ^(a)
Bond Strength	Plate	ASTM D522-93a and Alternate ¹
Abrasion Resistance	All	ASTM C704-01
Abrasion Resistance	Plate	Alternate ^(a)
Surface Area	All	Single-Point BET using Nitrogen
Pore Volume and Distribution	All	Hg Porosimetry or Gas Adsorption

The background of the slide is a photograph of an industrial facility, likely a power plant or refinery, featuring a tall smokestack on the left and a complex network of steel structures and piping. A semi-transparent blue grid is overlaid on the image, and a solid blue bar is at the bottom.

PANEL MEMBERS

Jared Cannon, *Southern Company Services, Inc.*

Thorsten Dux, *E.ON Engineering Corp.*

Hans Hartenstein, *Evonik Energy Services LLC*

Greg Holscher, *CERAM Environmental, Inc.*

Ken Jeffers, *Argillon LLC*

Questions

1. Do catalyst vendors and independent testing laboratories have an in-house protocol for testing catalyst samples (flow, temperature, gas composition, NH₃/NO_x, etc.) or do you use a protocol such as the one developed by the VGB? To what extent are SCR users specifying the test conditions?
2. In Germany, the VGB sponsors round-robin tests of catalyst samples by independent testing laboratories and catalyst suppliers. What value does this provide to users of SCR catalyst? Should this type of testing be conducted in the U.S.?



Questions

- 3. A utility usually takes catalyst sample(s) at the end of the ozone season for activity testing. Do you feel that this is adequate to define K/Ko vs. time? With the shift to year-round operation and less frequent SCR outages, will samples at one-year intervals or longer compromise catalyst management?**
- 4. What sort of trends are developing with respect to catalyst testing? Is there sufficient testing capacity to meet U.S. SCR users' needs in a timely fashion? Will this change with annual operation?**



Questions

5. Mercury oxidation is becoming an important aspect of SCR technology. Changes in the rate of mercury oxidation over time may become as important as activity for NO_x reduction. Do you do this testing now, or do you have plans to offer this testing in the near future?
6. How is SO₂ oxidation testing of low conversion catalysts, or low inlet SO₂ values, handled? These conditions may result in less than 1 ppm SO₃ change across the catalyst. How do you measure SO₂ oxidation and what precision do you think you have?

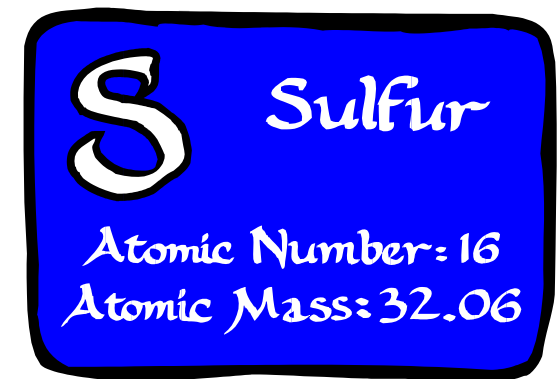
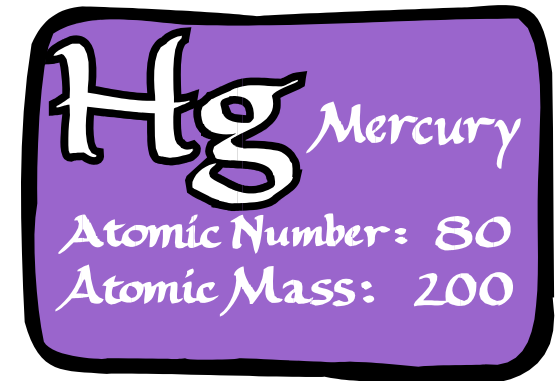

Questions

7. Are catalyst vendors performing or willing to perform testing of other vendors' products?
8. Do SCR users' understand how to specify catalyst testing conditions? How to interpret the data? Make use of it in a catalyst management program?

